

V-MOVE TRAILER MOVER



V-MOVE TRAILER MOVER

Trailers up to 40 000 kg

Move fully loaded trailers up to 40 000 kg effortlessly with the V-move Trailer Mover. This extremely powerful electric trailer mover comes equipped with a hydraulic lifting system with a lifting capacity of 14,000 kg, making even the heaviest trailers easy to handle. Enjoy greater efficiency and ease every single day.

Powerful and green

The V-move Trailer Mover features two extremely powerful electric motors, allowing you to work without noise or pollution. Its low-maintenance battery is easy to recharge with the external charger. If sustainability is a priority for your company, this quiet powerhouse is the perfect solution.

No certification required

This ultra-powerful electric tow tug is perfect for trailers of all shapes and sizes. It can replace a terminal tractor, especially for short distances, and requires no certification to operate. With zero emissions, the Trailer Mover is suitable for both outdoor and indoor use, with or without remote control.

Developed and manufactured in Leiden

Verhagen Leiden, our V-move Trailer Mover delivers top-notch Dutch quality you can depend on. Are you ready to embrace the power without the noise?





The V-move Trailer Mover is fully developed and produced by V-move in the Netherlands.



V-MOVE TRAILER MOVER / Features



Operation

The V-move Trailer Mover is easy to operate using the ergonomic tiller head. Standard features include stepless speed control, speed selector, and anti-crush protection.



Remote control

Thanks to the optional remote control, the operator can monitor the trailer from any angle. This significantly reduces the risk of damage and pinch-point hazards.



Compressor

The optional compressor allows the trailer's air brakes to be quickly released. Additionally, a special braking system is available that uses the trailer brakes to generate extra braking force on inclines or at loading docks.



Coupling

The hydraulic lifting system with fifth wheel coupling enables the trailer to be quickly hitched and unhitched.



Maintenance free battery

The large battery pack ensures the Trailer Mover can operate throughout the entire workday.



Tyres

Special solid tyres provide maximum traction on slippery and/or wet surfaces.

V-MOVE TRAILER MOVER 20T & 40T / Technical Specifications

	20T	40T
Maximum towing capacity	20 000 kg (≈ 44,092 lbs)	40 000 kg (≈ 88,185 lbs)
Maximum tractive force	19 000 N	54 600 N
Voltage	48 V	48 V
Drive system	Dual drive	Dual drive
Motor	2 x 5 kW	2 x 10 kW
Maximum lifting capacity	4500 kg (≈ 9 920.8 lbs)	14 000 kg (≈ 30,865 lb)
Lifting height	1400 mm (≈ 55 in)	1400 mm / 1500 mm (optional)
Brake system	Regenerative	Regenerative
Parking brake	Electromagnetic	Electrohydraulic
Horn	Yes	Yes
Battery indicator	Yes	Yes
Forward speed	5 km/h (≈ 3.1 mph)	5 km/h (≈ 3.1 mph)
Reverse speed	5 km/h (≈ 3.1 mph)	5 km/h (≈ 3.1 mph)
Standard drive wheels	Solid rubber	Solid rubber
Steering wheel	Polyurethane	Solid rubber
Machine weight including battery	1700 kg (≈ 3,748 lbs)	3600 kg (≈ 7,937 lbs)
Dimensions LxWxH	3114 x 1200 x 1000 mm	3270 x 1535 x 1000 mm
Standard battery	8 x 6 V 230 Ah AGM, maintenance-free	48 V 480 Ah full traction
Battery charger	External 230 V 40 A	External 230 V 55 A

V-MOVE TRAILER MOVER 20T / Dimensions (mm)

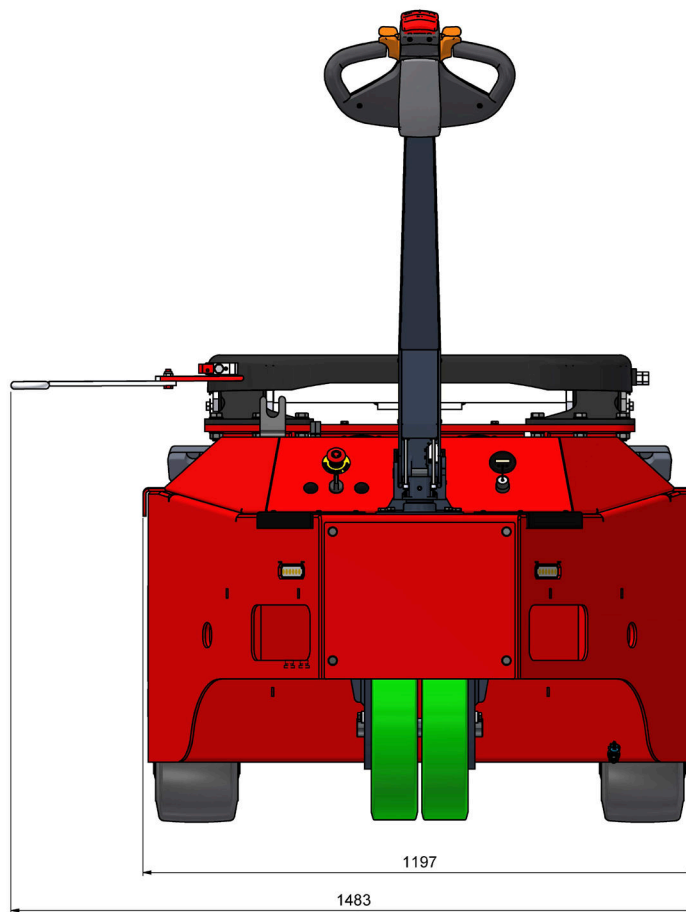
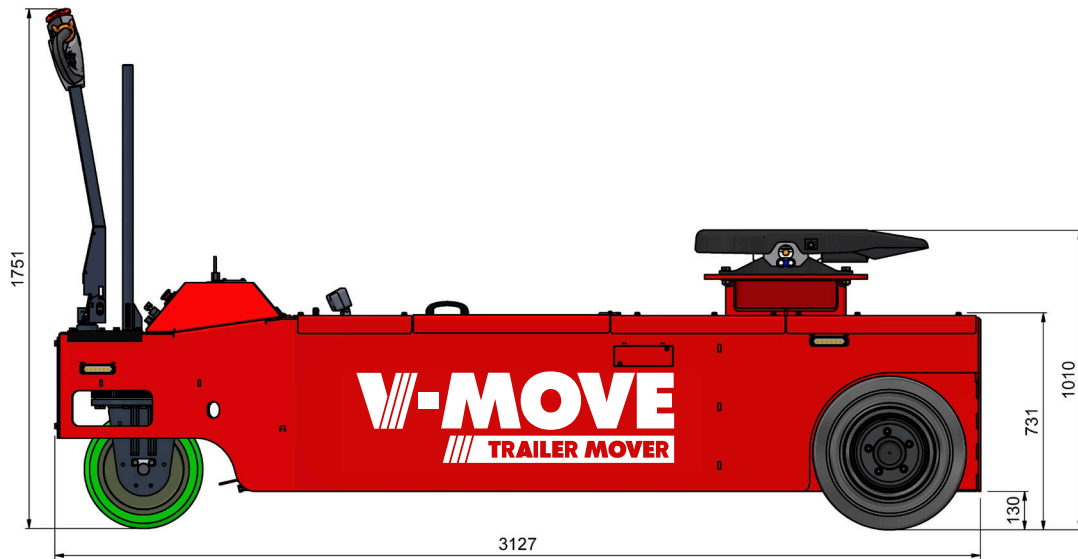

V-MOVE TRAILER MOVER 40T / Dimensions (mm)

